

VMC

VMC 1200



THE FUTURE OF COMMERCIAL ELECTRIC VEHICLES IS HERE.

The VMC 1200 from Vicinity Motor Corp. is a fully electric, class 3 truck which has the power and potential to transform the shipping industry in North America.

Powered by cutting edge Li-Ion battery technology that provides up to 150 kWh of power, the VMC 1200 can travel up to 150 miles on a single charge. Perfectly suited for ultra-quiet operation in urban environments.

Designed by Vicinity Motor Corp. leveraging our proven EV technology, the VMC 1200 is helping the transportation industry reduce costs, eliminate carbon emissions, and run a more efficient fleet.

www.vicinitymotorcorp.com

TECHNICAL SPECIFICATIONS

WEIGHT

GVWR	12,000 LBS
GVW	6,000 LBS
LOAD CAPACITY	6,000 LBS
GRADEABILITY	25 %

ELECTRICAL POWERTRAIN

TOP SPEED	65 MPH
MAX POWER	120 KW / 160 HP
MAX TORQUE	1200 NM / 800 FT LBS
RANGE	UP TO 180 MILES
LI-ION BATTERY	UP TO 150 KWH
ON BOARD CHARGER	8 KW
CHARGING	LEVEL 2 / 5 – 7 HRS LEVEL 3 / 2.5 HRS

CHASSIS

WHEEL BASE	132 IN
SUSPENSION	LEAF SPRING
HYDRAULIC BRAKES	ABS WITH REGENERATION
FRONT AXLE	4,000 LBS
REAR AXLE	8,000 LBS
TIRES	225 / 16 R 75

STANDARD FEATURES

AIR CONDITIONING
TILT TELESCOPIC
POWER WINDOWS
POWER DOOR LOCKS/KEYLESS ENTRY
3-PERSON SEATING
DRIVERS HIGH BACK COMFORT SEAT

DIMENSIONS

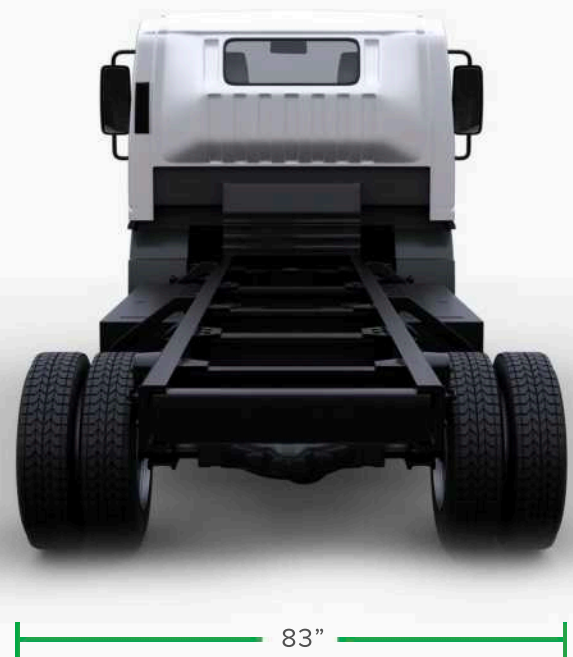
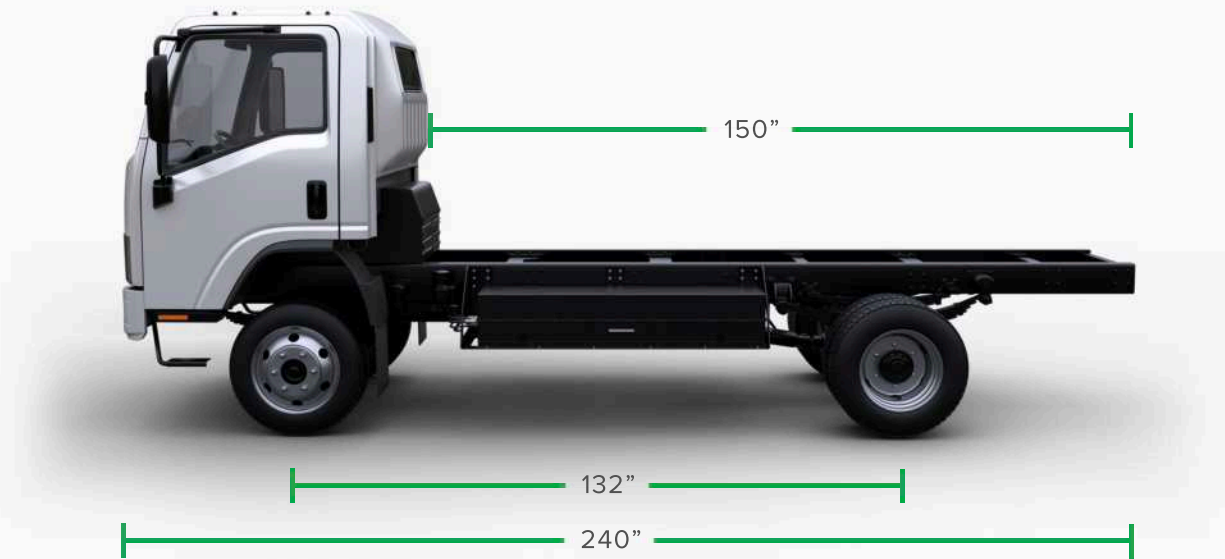



AVAILABLE FOR PRE-ORDER

PHONE +1.604.309.5971

EMAIL STU@VICINITYMOTOR.COM

WEB VICINITYMOTORCORP.COM

